

# Caliper mounting instructions

Thank you for purchasing this Moto-Master performance product. Please read these instructions carefully before attempting installation. \*

## Step 1

Remove Front wheel, original adapter bracket and caliper. Clean adapter mount contact areas.

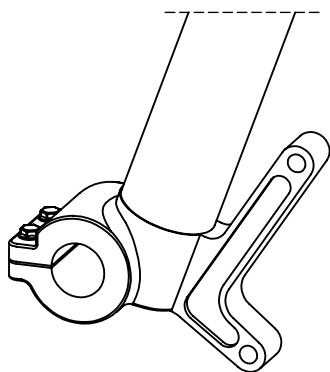

## Step 2

Install the Supermoto Racing adapter bracket to the Racing caliper with 2x M8x25mm bolt. (Bolt thread-length: 25mm)

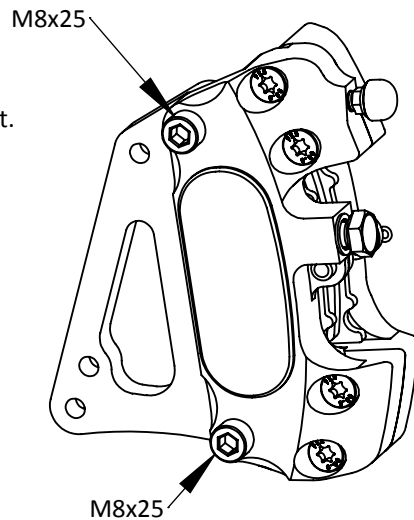

## Step 3

Install the bracket/caliper combo on front fork. Use original bolts when no extra bolts are supplied in Moto-Master package.

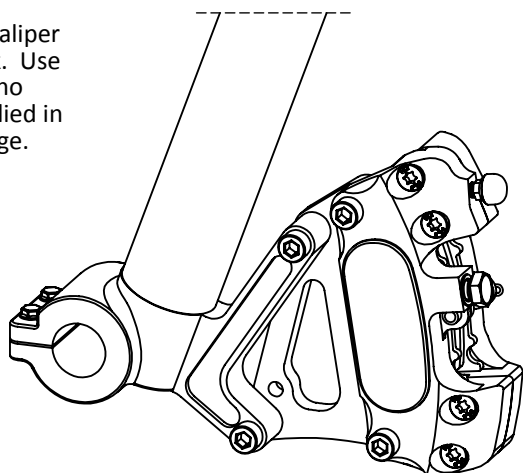

## Step 4

Connect the brake line together with 2 new copper washer rings.

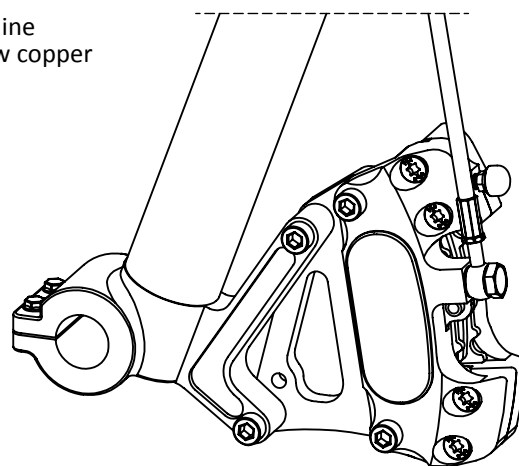

## Step 5

Install the brake disc on the wheel (see disc installation instructions) and reinstall the wheel on the bike. Make sure the brake disc is between both brake pads. Tighten all bolts according to the following specifications;

### Torque specs:

Bracket - front fork: 22Nm

Caliper - bracket bolts: 22Nm

Banjo bolt: 17Nm

Torque of wheel axle bolt and other bolts according to motorcycle manufacturer specifications. Consult motorcycle service manual.

## Step 6

Check for proper brake disc to caliper alignment. The brake disc should be positioned exactly in the center of the caliper. (From top view)

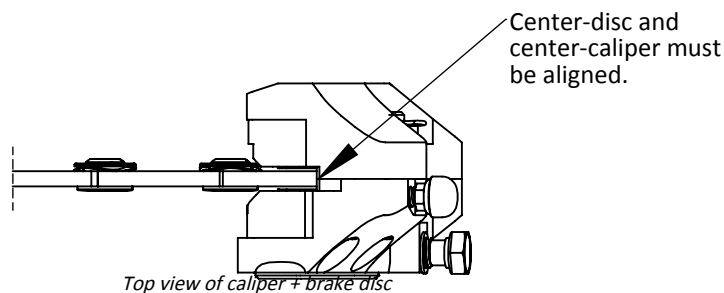

## Step 5

Refill the system with new DOT-4 brake fluid or higher and bleed carefully so NO air remains in the brake system. Next, lift front wheel and operate front brake multiple times. Check for proper engagement and release of front brake. After releasing the brake the wheel should spin free of drag.

Note: New brake pads- and discs need bedding in. Brake performance can be severely reduced during this period. Avoid continuous- or harsh brake actions during the first 200km/125 miles. Repeated hard braking during the bedding in period can result in gripping, brake-loss and damaged pads.

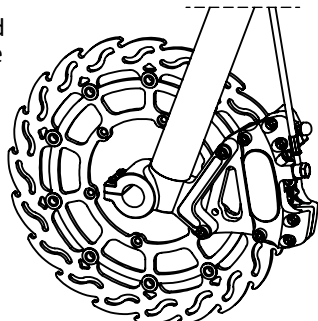

\*Consult a certified dealer of professional mechanic if you are not fully qualified in motorcycle maintenance. Moto-Master cannot be held responsible for any damage or injury caused by incorrect product mounting, disregarding specifications and these instructions, or product mounting by an unqualified third party. Inspect brake system for correct functioning, proper bolt tightening and possible damage before each ride.



For more info, check:

[www.moto-master.com](http://www.moto-master.com)