

MXC Caliper overhaul instructions

Thank you for purchasing this Moto-Master performance product. Please read these instructions carefully before attempting installation. *

Step 1

Remove R-clips (1), brake pad pin (2), brake pads (3), retainer clip (4) and banjo bolt (5). Measure the thickness of the brake pad friction material. When the thickness is under 1 mm, replace brake pads.

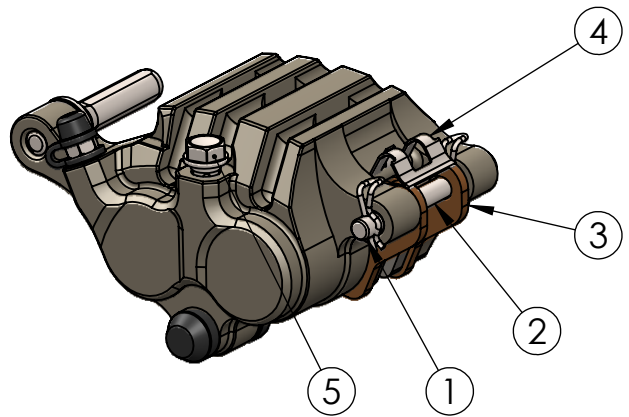

Step 2

Remove old caliper pistons (6) and piston seal rings (7). Clean caliper body (8) with a non-aggressive chemical (no basic soda or brake cleaner). Rinse and dry thoroughly. No water is allowed to remain!

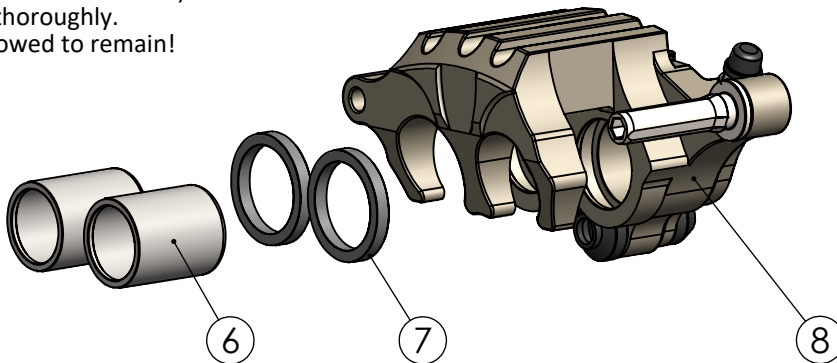

Step 3

Apply special supplied grease on piston seal rings (7) and the outside of the pistons (6). Insert piston seal rings (7) followed by the pistons (6). Make sure the closed sides of the pistons (6) are facing towards the caliper body (8) during installation.

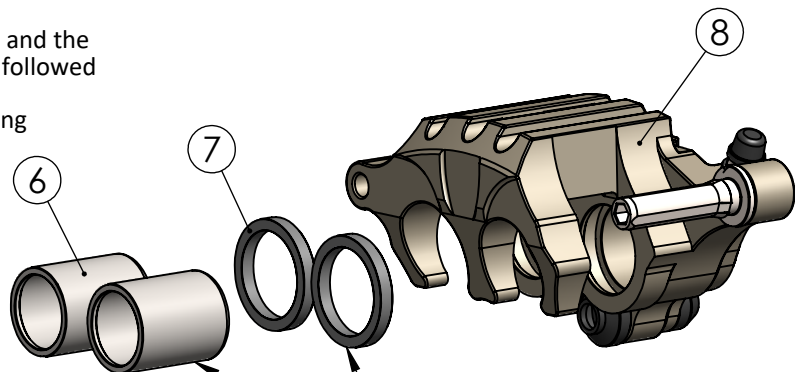

Step 4

Reinstall the brake caliper according to the MXC Caliper Mounting and Safety Instructions.

Apply supplied grease

Step 5

Refill the brake system with new brake fluid from a sealed container and bleed carefully so no air remains in the system (only use DOT 4 or DOT 5.1 brake fluid).

*Consult a certified dealer of professional mechanic if you are not fully qualified in motorcycle maintenance. Moto-Master cannot be held responsible for any damage or injury caused by incorrect product mounting, disregarding specifications and these instructions, or product mounting by an unqualified third party.



For more info, check:

WWW.MOTO-MASTER.COM